

World Darts Federation **Americas Region**

GENERAL TOURNAMENT RULES **AND REGULATIONS**

2008

As amended in AGM, Barbados, 2006
Malcolm Spicer, President, WDFARC

INDEX

Glossary

A. TOURNAMENT PLAY

1. Tournament and Championship Organization

2. Playing Rules for Americas Cup

3. WDFARC GENERAL
TOURNAMENT RULES

(a) General Rules

(b) Entry

(c) Registration

(d) Draw

(e) Order of Play

(f) Practice

(g) Tournament Matchplay

(h) Attire

(i) Advertising

(j) Amendments/Additions

**B. TOURNAMENT RULES FOR THE
AMERICAS CUP**

**C. PLAYING RULES FOR THE
AMERICAS CUP**

GLOSSARY

WDFARC -	WDF Americas Region Council (WDFARC)
Playing Rules -	Refers to the WDF Playing Rules of the Sport of Darts, and shall be the rules used in all Tournament play.
Tournament Rules -	Those Rules put down by the WDFARC for that particular Tournament regarding the format of the match or matches and the proper functioning of the event.
WDFARC General Rules -	Those Rules laid down by the WDFARC which refer to all Tournaments and events under the jurisdiction of the WDFARC.

A. TOURNAMENT PLAY

1. TOURNAMENT AND CHAMPIONSHIP ORGANIZATION

The WDFARC shall endeavour to spread the Tournament equally among the member Associations.

- (a) The Host Country is responsible for finding sponsors for WDFARC Tournaments and Championships.
- (b) All darts events run under the jurisdiction of the WDFARC, shall have as its officials and organizers, the WDFARC, and/or any other person(s) appointed by the WDFARC.
- (c) The member Association hosting the darts event shall be responsible for:-
 - i) A suitable venue large enough to accommodate the Tournament, and to display flags.
 - ii) Playing equipment such as darts stands, boards, suitable lighting, fixed oches, and miscellaneous equipment.
 - iii) Referees and scorers.
 - iv) The provision of refreshments, in one form or another, to players and spectators.
 - v) Assisting the visiting players in arranging their accommodation.
 - vi) Correct trophies for the event

2. PLAYING RULES

These shall be the Playing Rules of the Sport of Darts as issued by the WDF. Where a rule is not covered by the WDF rule then the ruling of the WDFARC Organizers will be final and binding,

3. GENERAL TOURNAMENT RULES

a) General Rules

- i) The WDFARC reserves the right to seed teams in any draw when deemed necessary.
- ii) All players or teams must play within the WDFARC General Tournament Rules and the Playing Rules of the WDF. plus any supplementary Rules laid down in any form or program.
- iii) Any player or team failing to comply with any of the Rules outlined in (ii) above shall be liable to disqualification from the event.
- iv) The interpretation of the Rules laid out , in relation to a Darts Event shall be determined by the Executive whose decision is final and binding.
- v) Any matter not expressly covered by the Rules shall be determined by the WDFARC or their representatives, whose decision is final and binding.
- vi) All darts players and teams shall play under the supervision and direction of the WDFARC appointed organizers and officials in the Darts Event run under the jurisdiction of the WDFARC.
- vii) No player or team, having once been knocked out of a "knockout" Tournament shall play again in that Tournament, either as a substitute for another player or team, or in his, or their, own right.
- viii) If a player or team representative is not present at the official presentation ceremony to receive trophies or prizes, without prior notification and permission of the WDFARC organizers and officials, then that player, or team representative shall forfeit the right to receive any such trophies or prizes that may be due.
- ix) In the event of a player, or team, being involved in or causing, actions considered to have brought the Sport of Darts into disrepute, then that player, or team, shall be subject to disciplinary measures being taken against the player, or team, which could mean the imposition of fines, suspensions or other penalties.

b) **Entry**

- i) Entry to all WDFARC Tournaments is restricted to WDF members only. Non members may play in their first tournament but must become a member of the WDF in order to participate again in the same tournament.
- ii) Admission Fees to Tournaments venues and Entry Fee to Tournaments are not refundable.
- iii) Entry Fees and admission Fees to all WDFARC Tournaments will go to the WDFARC.
- iv) All entries must be made on the official entry form, fully completed, and must be returned together with the appropriate entry fee, on or before, the specified closing date.
- v) Only players named on the entry forms as the competing individual, or team, shall be able to play in the respective Darts Event.
- vi) The WDFARC appointed organizers reserve the right to refuse, or cancel, any entrant at any stage during a Darts Event, and their decision shall be final and binding.
- viii) All players in the Americas Cup must have resided in that country that they are playing for, for a period of no less than 6 (six) calendar months prior to the date of the competition.

c) **Registration** (In this section the *event* is the Americas Cup)

- i) All Tournament players, or teams, shall register at each darts event at the scheduled times.
- ii) Any Tournament player, or team, failing to register by the notified time shall be eliminated from that respective event.
- iii) Only six (6) minutes shall be allowed from the time of calling for the player, or team, to the Tournament desk or matchboard, whichever is called for. Failure to show within this time will result in the forfeit of that leg, set, or match, whichever is applicable.

- iv) Any player, or team, has the right to be advised of the approximate time of the next match the player, or team, is scheduled to play.
- v) The WDFARC appointed organizers reserve the right to alter the scheduled times and playing format whenever such is recommended by the WDFARC Executive.

d) Draw

- i) There will be only one draw for opponents which shall be conducted prior to the Darts Event, the bracket system being adopted in knockout events.
- ii) Draw sheets will be displayed where possible at the Tournament desk, or at a convenient point in the venue.
- iii) Times indicated on a draw sheet will be for guidance only, and players should be prepared to be called up to forty-five (45) minutes before the time indicated.
- iv) No substitutes shall be allowed in an Individuals' darts event.
- v) Substitutes may be allowed in some team events in certain Tournaments in which case the Tournament Rules for that event will specify such.

e) Order of Play

- i) SEE "Playing Rules of The Sport of Darts"
WDF
- ii) When a set is made up of a number of legs (e.g. 3 or 5 legs) then players shall throw for the bull only in the first leg. The winner(s) shall throw first in the first leg and each alternate leg thereafter. The loser(s) shall throw first in the second leg and each alternate leg after that. The flip of a coin shall determine who throws first at the bull.

f) Practice

- i) Each player is allowed 6 practice darts before the match commences and the Game is called to play by the referee on an assigned matchboard. No other practice darts may be

thrown during the match, without the prior permission of the referee.

- ii) No practice shall be allowed on unassigned matchboards after the darts event has officially started.
- iii) Any practice boards are for the exclusive use of the Tournament players or teams ONLY.

g) Tournament Matchplay

- i) No person shall be allowed in the playing area other than the board referee, scorer and assigned players, or teams.
- ii) Only designated officials should be in front of the oche during a match. These officials are expected to restrict their movement to a minimum during a player's throw.
- iii) A player's opponent should stand at least 2ft. behind the player at the oche.
- iv) A raised oche must be used at all WDFARC promoted Tournaments.
- v) A maximum time limit of three (3) minutes, subject to the referee's permission, shall be allowed in the event of the player requiring to leave the playing area in exceptional circumstances during the course of a leg, set or match, whichever is applicable.

h) Attire (general)

- i) Players are not permitted to wear shorts, blue jeans, hats or open toed shoes or sandals during matchplay, unless it is for medical reasons.
- ii) Players should wear their Association's approved shirt, or their team's playing colours, or adhere to the dress code, whichever is applicable.
- iii) No advertising shall appear on any player's attire unless permission is given by the Tournament's appointed organizers.

i) Advertising

The WDFARC reserves the right to protect their sponsors' interests with regards to any advertising material used by the players, teams, organizers, or other sponsors, during a WDFARC event.

j) Drinking and Smoking

- 1) Americas Cup - No Smoking by Players or Spectators in the venue
- 2) No drinking will be allowed in the designated playing area in any on-stage event.

1st Offense.....verbal warning

2nd Offense.....forfeit of that game

k) Amendments/Additions

The WDFARC reserves the right to add to, or amend, any, or all, of the Playing Rules, WDFARC Tournament Rules or Tournament Rules, at any time to meet any purpose deemed to be necessary at the time.

Playing Rules

In the absence of specific Playing Rules for the Americas Cup, the Playing Rules for the Caribbean Darts Organization should be followed.

Player Eligibility

On motion proposed by Cayman, seconded by Jamaica and carried unanimously it was agreed that the eligibility rule for a player to represent a country should be amended by adding the words "This rule refers only to non-Nationals of that country." The effect of this change is that a player may represent a country if they hold a passport issued by that country (even if they live outside that country) or if they have lived there for no less than 6 months prior to the date of the competition (if they do not hold a passport issued by that country).

TOURNAMENT RULES

FOR THE

AMERICAS CUP

2008

As amended, AGM Barbados, 2006

Malcolm Spicer, President, WDFARC

1. TEAMS

A team is made up of 2, 3 or 4 men and 2, 3 or 4 women.

(minimum 2 men, maximum 4 men)

(minimum 2 women, maximum 4 women)

Manager

Coach

A country may play any of their registered players in any of the matches in the team event. (country v country). That is different players may play in different blocks of the team event.

Two men and two women entrants for each country in the knockout Championship. Once entered they cannot be changed.

2. EVENTS

The following events are both part of the Americas Cup.

The events are 2 separate events.

The Americas Cup Winners will be determined by the winners of the Team Event

Knockout Men's and Women's Singles are separate events.

The knockout singles rounds and each team event will be scheduled to run alternately

A) TEAM EVENT.

The first round of the team event will be made up of 4 leagues of 3 or 4 teams (dependent on number of entrants)

Countries play one another in a round-robin format within that league.

The top two teams from each league will go through to a knockout stage.

Points are awarded according to the score in the match and will be accumulated in order to reach the knockout stage.

Once the knockout stage is reached matches will only be played until one team reaches 7 points. That team will go through to the next knockout stage.

The winner of the knockout stage is the Americas Cup Winner.

The match format is:-

4 blocks of games. Sets in a block to be played at the same time and in the order listed below. Each set worth 1 point. A set being best of 3 (or 5) games (2-0 or 2-1) (3-0, 3-1 or 3-2 for 5 game sets).

- | | |
|---------|--|
| Block 1 | 2 Mixed Doubles, 501 best of 3 |
| Block 2 | 4 Mens Singles, 501 best of 5
4 Womens Singles, 501 best of 3 |
| Block 3 | Mens Doubles, 501 best of 3
Womens Doubles, 501 best of 3 |
| Block 4 | Team Game, 1001, 1 leg |

There will be a trophy for this TEAM EVENT

Each set counts 1 point making a maximum of 13 points per match.

B. KNOCKOUT EVENT

1 MEN'S SINGLES AND LADIES SINGLES EVENTS

Each country is allowed up to 2 men in the men's singles and up to 2 women in the ladies singles tournament. A knockout draw is made to keep players from the same country from meeting each other in the first two rounds where possible.

2. FORMAT

All sets in each event are 501 SS DF
except team game which is 1001 SS DF
(Men's Singles finals is best of 5 x 501)
(Women's Singles finals is best of 5 x 501)

3. STARTING

Middle up in the first leg only. Coin toss to decide who middles first. Winner of middle goes first in first leg and all alternate legs. Loser goes first in second leg and each alternate leg thereafter.

For each set of 3 or 5 legs, the playing order for the deciding leg should be determined by throwing for the bull again, with the winner of the original bull throw having the option of throwing first or second for the bull before the deciding leg.

4. **DRESS CODE**

I. SHIRTS

Must be identical in all aspects except personal name.

II TROUSERS/SKIRTS

Must be uniform in colour. No Blue jeans. No jeans with patches, studs or multiple zippers. Jean-like material in a dress pant will be acceptable, except for blue.

III FOOTWEAR

No sandals, flip-flops, open-toed or open-heeled shoes will be allowed.

A sandal is defined as any shoe with a strap around the back.

All team must wear the same colour shoes.

Black is recommended but not mandatory.

IV HEADWEAR

No headwear of any sort is to be allowed.

No headphones, earphones or earmuffs are allowed

Earplugs may be worn so long as they are worn inside the ear.

V Rules III and IV may be **waived** with a valid current medical certificate.

VI These rules apply **to the whole team** and a team is made up of a manager, coach, 4 men and 4 women (max). There is no restriction on supporters' dress code.

VII The above rules come into effect **following the coin-toss** that starts that set.

VIII Advertising. A patch of no more than 4" by 4" can go onto sleeves but any other advertising on the shirts must have the prior approval of the tournament organizers to avoid possible sponsor conflict.

5. **PRACTICE BOARDS**

Practice boards will be provided. The competition boards are NOT to be used for practice during play.

6. **PLAYING RULES**

Playing Rules are those laid out in the "Playing Rules of the Sport of Darts" of the WDFARC.

7. **TOURNAMENT RULES**

Tournament Rules are those laid out in the "Tournament Rules and Regulations" of the WDFARC.

8. **REGISTRATION**

Countries may register up to 4 men and 4 women at the time designated. Only these players may play in any of the above events. No substitutes will be allowed under any circumstances for the men. A full squad will consist of 4 men, 4 women, a coach, and a team manager.

9. **SMOKING**

No smoking allowed anywhere within the Tournament venue by Players or spectators.

10

Traditionally, teams exchange small gifts or souvenirs during the course of the competition, eg liqueur miniatures, key rings, flag pins etc.

11.

In the event of a tie in the team event the final decision will depend on how the teams fared against each other in that event.

13. TROPHIES

The following trophies should be provided

<u>Provider</u>	<u>For each participant</u>	<u>Event</u>
Host	(10 per country) (160)	small medallion of participation
WDF	Floating Trophy	Americas Cup Winners
Host	To keep Trophy	Americas Cup Winners
WDF	MEDALS (10)	Americas Cup Winners
WDF	MEDALS (10)	American Cup Runners-Up
WDF	MEDALS (20)	Americas Cup 3 rd /4 th
WDF	MEDAL	Americas Cup Singles Winner, Men
WDF	MEDAL	Americas Cup Runner-up, Men
WDF	MEDALS (2)	Americas Cup 3 rd /4 th , Men
WDF	MEDAL	Americas Cup Singles Winner, Women
WDF	MEDAL	Americas Cup Runner-up, Women
WDF	MEDALS (2)	Americas Cup 3 rd /4 th , Women
Host	Trophies for Most 180's, Lowest game, Highest out, men and women)	

C. PLAYING RULES FOR THE AMERICAS CUP

- 1.01 Any matter not expressly covered by the Playing Rules shall be determined by the WDFARC whose decision shall be final and binding.
- 1.02 The Playing Rules of the WDFARC are those of the WDF except in the cases where no specific rule exists, to the knowledge of the Executive, and the Executive has made a ruling. If the specific rule is, in the future, clarified by the WDF it shall be so changed into the rulings of the WDFARC.
- 1.03 All players or teams shall play within the Playing Rules of the WDFARC and, where necessary any supplementary rules laid down by any Association in their own league or events, or by the WDFARC in its own tournaments and events.
- 1.04 Players shall have their own darts.
- 1.05 Darts shall not exceed 12ins (30.5cm) in length nor weigh more than 50 grams.
- 1.06 "Hammerhead" type darts and darts with spring loaded tips and points will be allowed.
- 1.07 A throw shall consist of three darts and shall begin when the player sets up at the oche and shall end when he retrieves the darts from the dartboard.
- 1.08 A player may change his darts at any time during a leg, set or match, but not during his throw unless the referee is satisfied that one or more of the darts is broken beyond repair within three (3) minutes.
- 1.09 A player shall be given three (3) minutes in which to throw his three darts. This includes time needed to repair or change flights, shafts or points. Any darts thrown in that throw after three minutes will not count.
- 1.10 Players shall have the right to request a check on the height of the dartboard, the distance from the oche, or the diagonal distance from the board to the oche, prior to the start of the match.
- 1.11 A player shall be called for three (3) times for his game with a two (2) minute wait between calls. Failure to show two (2) minutes after the third call will result in that leg, set or match, whichever is applicable, being forfeited.
- 1.12 During the throw only the player throwing may communicate with the scorer as to score thrown, or remaining.

- 1.13 The scorer may only indicate what is left and not how to finish (32 left, NOT double-16).
- 1.14 No prompting shall be allowed by any person while the player is at the oche. A first offense will be covered by a warning. Any subsequent offense by the same player will result in the forfeiture of that leg.
- 1.15 A player may step back from the oche at any time and confer with anybody.
- 1.16 In all line-ups the order of play shall be the same order as is written down on the score sheet.
- 1.17 If a player throws out of turn in a team game (doubles, triples etc.) then that player's throw that should have thrown will be forfeited and the score of the player that threw out of turn will not count providing it is pointed out before that team's next throw.
- 1.18 A player will be allowed six (6) practice darts from the time the referee or scorer calls for the game.

2. THE THROW

- 2.01 A throw shall consist of three (3) darts unless a leg, set or match is finished in less than three darts.
- 2.02 All darts are to be thrown by, and from, the hand.
- 2.03 Any dart bouncing off, or falling out of the dartboard shall not be rethrown, unless it is the dart thrown to decide on who throws first at the start of a leg, set or match. Such a dart may be rethrown.

3. STARTING AND FINISHING

- 3.01 Every leg must be started by two players throwing for the bull unless tournament or event rules state otherwise.
- 3.02 In matches other than singles any listed player may be the one to throw for the bull.
- 3.03 In matches other than singles, the first player listed will be the one to throw in the game.
- 3.04 When throwing for the bull, closest to the bull goes first. If the first dart thrown hits a single bull or a double bull it shall be removed before the

opponent's dart is thrown. If both players hit double bull or both players hit single bull, then the darts shall be rethrown, the second player's team now throwing first (i.e. the same person need not rethrow).

- 3.05 Hitting double bull when deciding on who throws first in a game does not constitute the start of a game and does not score.
- 3.06 A game shot called by the referee is valid only if the darts thrown achieve the required finish as stated by the scorer/referee, and remain in the dartboard until retrieved by the thrower after "Game" is called.
- 3.07 Any dart mistakenly thrown by a player, after scoring the required double shall not count, as the respective leg, set or match is concluded by the dart scoring the required double.
- 3.08 Centre Bull (or Double Bull) shall count as 50, or double-25 and may end a game as a double.
- 3.09 The "Bust Rule" shall apply in all games of *-01. That is, if a player scores more than the score required to end a leg then the score reverts back to what it was at the beginning of the throw.

4. SCORING

- 4.01 A dart shall only score if the point remains in, or touches, the face of the dartboard within the outer double wire, and having been called, shall be retrieved from the dartboard by the thrower. If the dart falls out before being retrieved it shall not count, even if the scorer has called it, and the score is amended as necessary.
- 4.02 Darts shall be retrieved from the dartboard, by the thrower, but only after the score has been called by the scorer or referee.
- 4.03 A protest about the score attained after the retrieval of the darts may not be upheld.
- 4.04 If a dart is supported by other darts it shall only score if the point of the dart is touching the dartboard in the part described above, in 4.01.
- 4.05 The score is counted from the side of the segment wire in which the point of the dart enters, and remains in, or touches, the face of the dartboard.
- 4.06 All requests to check the scores recorded, or substitutions made, must be made before the player or team's next throw.

- 4.07 The first player or team to reduce their scores required to exactly zero by obtaining the required double (in games of -01) shall be the winner of that leg, set or match, whichever is applicable.
- 4.08 Any dart travelling over four (4) feet from the throwing line will be counted as thrown.
- 4.09 If a scorer or referee communicates the wrong number required to finish, then that number should be the score left, even if it is wrong, unless an objection is made before the dart is thrown. In such a case the opposing player (team) may make the objection.
- 4.10 When a player asks the scorer for the score remaining, in mid throw, the scorer must write that score, clearly visible, on the scoresheet.
- 4.11 The actual score required must be shown on the score sheet, or score board, clearly visible, in front of the players and the referee.

5. DARTBOARDS

- 5.01 All dartboards shall be of the "Bristle" type.
- 5.02 All dartboards shall be of the 1-20 clock pattern.
- 5.03 The inner narrow band shall score treble the segment no.
- 5.04 The outer narrow band shall score double the segment no.
- 5.05 The outer centre ring shall score 25.
- 5.06 The inner centre ring shall score 50 (or double-25) and shall be called "the bull".
- 5.07 The dartboard shall be fixed such that the perpendicular height from the centre of the bull to the floor, at the same level as the oche (line) shall measure 5ft. 8ins. (1.73m).
- 5.08 The four colours of the dartboard shall be:-
Black, Red, Green and off-White (yellow).
- 5.09 The dartboard shall be fixed such that the "20" segment is coloured Black and shall be at the top of the dartboard.

6. OCHES (LINES)

- 6.01 Where possible, a raised oche should be used in all darts games. A raised oche must be used in all WDFARC events and tournaments.
- 6.02 A raised oche at least 1 1/2ins. high and 2ft. long (38mm high and 610mm long), must be placed in position at the minimum throwing distance and shall measure from the back of the raised oche 7ft. 9 1/4ins. (2.37m) along the floor to a plumb line at the face of the dartboard.
- 6.03 The diagonal distance from the centre of the bull to the back of the raised oche at floor level shall measure 9ft. 7 1/2ins. (2.93m).
- 6.04 During matchplay no player shall tread on any part of the raised oche, nor shall the player deliver any dart with his feet in any position other than behind the toe edge of the raised oche.

- 6.05 A player wishing to throw a dart, or darts, from a point either side of the raised oche must keep his feet behind an imaginary straight line extending from either side of the raised oche.
- 6.06 Any player in breach of rule 6.04 or 6.05 shall first be warned by the referee. Any dart thrown subsequently, in breach of these rules, shall not score and shall not be rethrown.
- 6.07 In regular season play, the word "line" may be substituted for "raised oche" in this section.

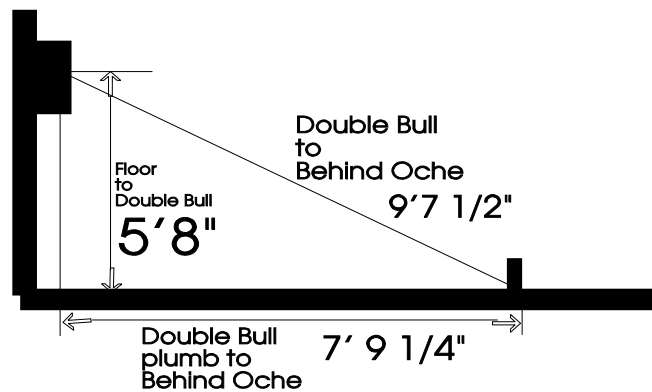

Centre Bull Height.....	5ft.8ins. (1.73m)
Minimum Throwing Distance.....	7ft.9 1/4ins. (2.37m)
Diagonal - Bull to back of Oche.....	9ft.7 1/2ins. (2.93m)
Height of raised Oche.....	1 1/2ins. (38mm)
Width of raised oche.....	2ft. (61cm)